

CANDIDATE
NAME

--

CENTRE
NUMBER

--	--	--	--	--

CANDIDATE
NUMBER

--	--	--	--

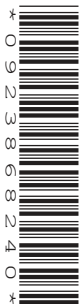

COMBINED SCIENCE

Paper 2

5129/21

May/June 2015

2 hours 15 minutes

Candidates answer on the Question Paper.

No Additional Materials are required.

READ THESE INSTRUCTIONS FIRST

Write your Centre number, candidate number and name on all the work you hand in.

Write in dark blue or black pen.

You may use an HB pencil for any diagrams, graphs or rough working.

Do not use staples, paper clips, glue or correction fluid.

DO NOT WRITE IN ANY BARCODES.

Answer **all** questions.

Electronic calculators may be used.

You may lose marks if you do not show your working or if you do not use appropriate units.

A copy of the Periodic Table is printed on page 24.

At the end of the examination, fasten all your work securely together.

The number of marks is given in brackets [] at the end of each question or part question.

This document consists of **21** printed pages and **3** blank pages.

1 Fig. 1.1 shows representations of elements, compounds and mixtures.

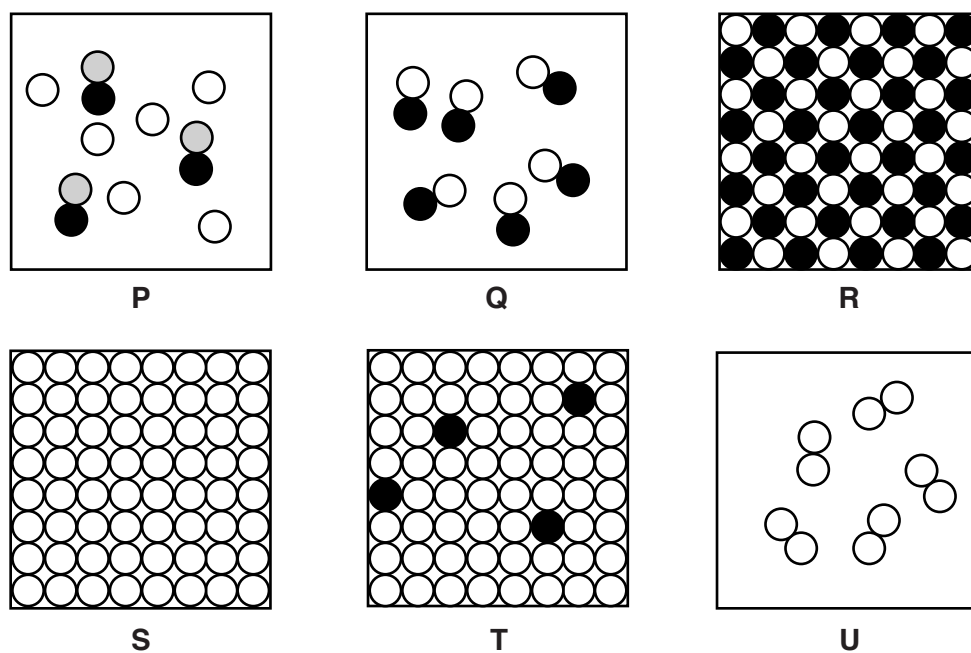

Fig. 1.1

Choose the letter on the diagram which represents

- (a) an element in Group VII of the Periodic Table,
- (b) a metallic element,
- (c) brass,
- (d) a diatomic compound,
- (e) a mixture of two gases.

[5]

2 Use words from the list to complete the sentences below.

Each word may be used once, more than once or not at all.

- | | | | |
|-----------------------|-------------------|------------------|-----------------|
| absorbed | amylase | excretion | extended |
| extra-cellular | fibrinogen | glycogen | kidneys |
| | liver | protein | |

In the alimentary canal, the enzyme digests starch.

This type of digestion is

Maltose is produced which is converted to glucose in the cells of the small intestine.

The glucose is into the blood.

If there is too much glucose in the blood, it is converted into

and stored in the

[5]

- 3 Fig. 3.1 shows a block of iron with dimensions of 5.0 cm × 2.0 cm × 4.0 cm.

The block is not drawn to scale.

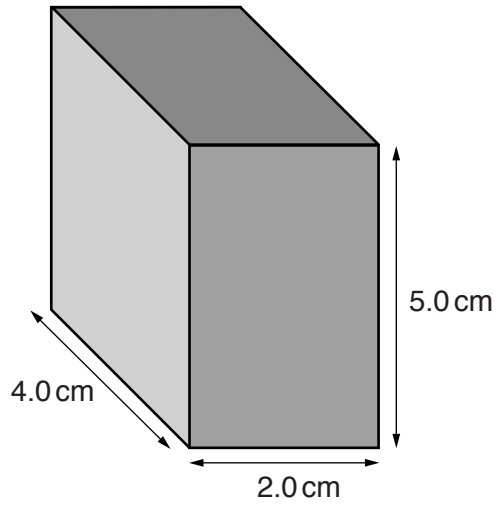

Fig. 3.1

The block has a mass of 316 g.

- (a) Calculate

- (i) the volume of the block,

volume = cm³ [1]

- (ii) the density of iron.

density = unit [2]

- (b) State why iron, rather than steel, is used for the core of electromagnets.

.....
 [1]

- 4 Pentane decomposes when it is heated in the presence of a catalyst to produce ethene and another hydrocarbon Y.

The equation for the reaction is

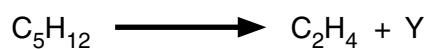

- (a) (i) State the formula of the hydrocarbon Y.

.....[1]

- (ii) State the name of the homologous series to which Y belongs.

.....[1]

- (b) Complete the following sentences about ethene.

Ethene is known as an hydrocarbon because it contains a carbon to carbon double bond.

When bromine water is added to ethene, it changes colour from brown to

.....

Ethene undergoes polymerisation to form poly(ethene).

In this process, ethene is known as a [4]

5 Fig. 5.1 shows a section through a leaf of a dicotyledonous plant.

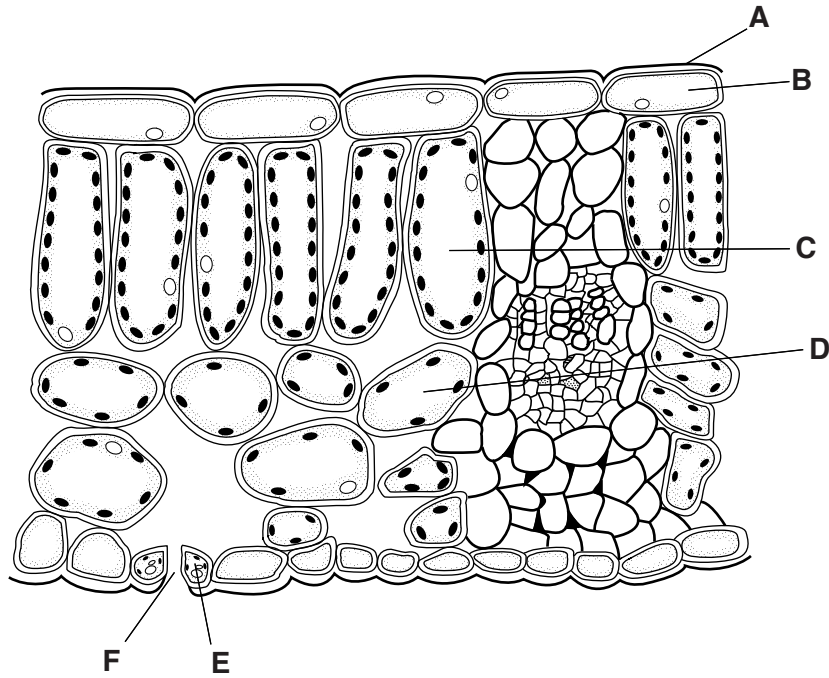

Fig. 5.1

(a) State the letter in Fig. 5.1 which identifies

- (i) an epidermal cell,
- (ii) a palisade mesophyll cell,
- (iii) a stoma.

[3]

(b) Complete the word equation for photosynthesis.



[1]

(c) State and explain the role of chlorophyll in photosynthesis.

.....

 [2]

(d) State where carbon dioxide and where water enters a plant.

carbon dioxide

.....

water

.....[2]

6 A simple a.c. generator consists of a magnet rotating inside a coil of wire.

Fig. 6.1 shows how the voltage output of the generator varies with time.

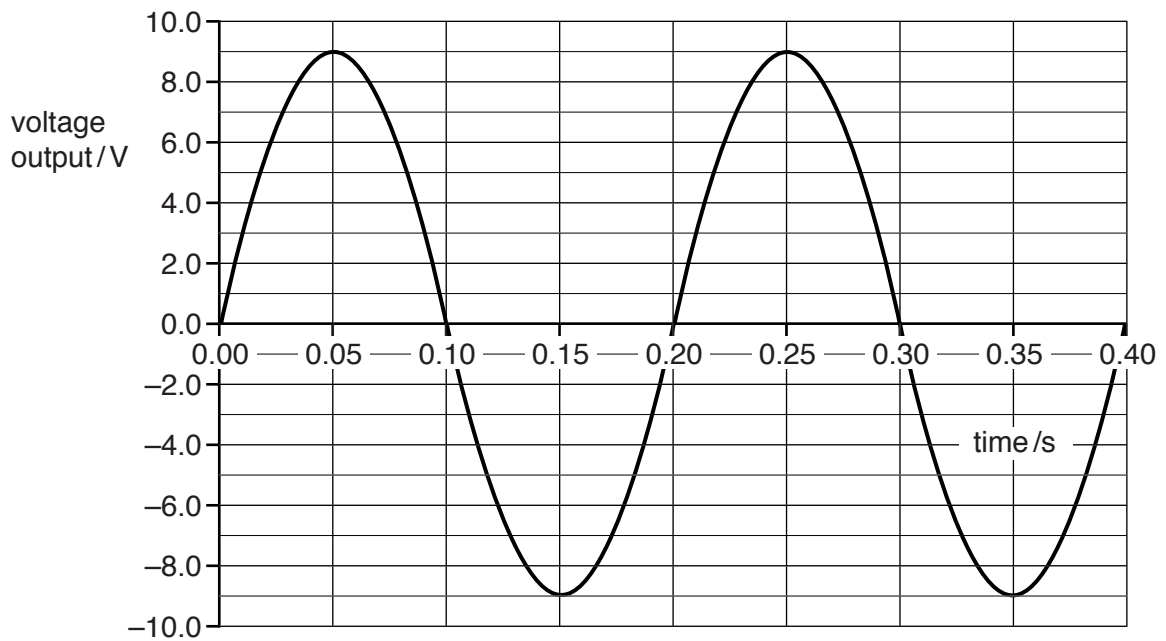

Fig. 6.1

(a) Use Fig. 6.1 to determine

(i) the time for one complete rotation of the magnet,

time = s [1]

(ii) the maximum voltage output.

voltage output = V [1]

(b) State one way in which Fig. 6.1 changes when the magnet is rotated more quickly.

.....

.....[1]

- 7 A resistor in a circuit produces 20 J of heat when 40 C of charge passes through it in 16 s.

Calculate

- (a) the current in the resistor,

current = A [2]

- (b) the potential difference (p.d.) across the resistor.

p.d. = V [2]

- 8 The oxide of an element, X_2O_3 , reacts with magnesium to produce magnesium oxide and element X.

The equation for the reaction is



The relative molecular mass of X_2O_3 is 152.

- (a) (i) Calculate the relative atomic mass of element X.

[A_r : O, 16; Mg, 24]

relative atomic mass =[1]

- (ii) Use the Periodic Table to identify element X.

.....[1]

- (b) (i) Calculate the mass of magnesium that reacts with 152 g of X_2O_3 .

mass = g [1]

- (ii) Use the answer to (b)(i) to calculate the mass of the oxide that reacts with 3.6 g of magnesium.

mass = g [1]

- (c) Explain why the oxide is said to be *reduced* during the reaction.

.....
[1]

9 Fig. 9.1 shows a pendulum in two different positions.

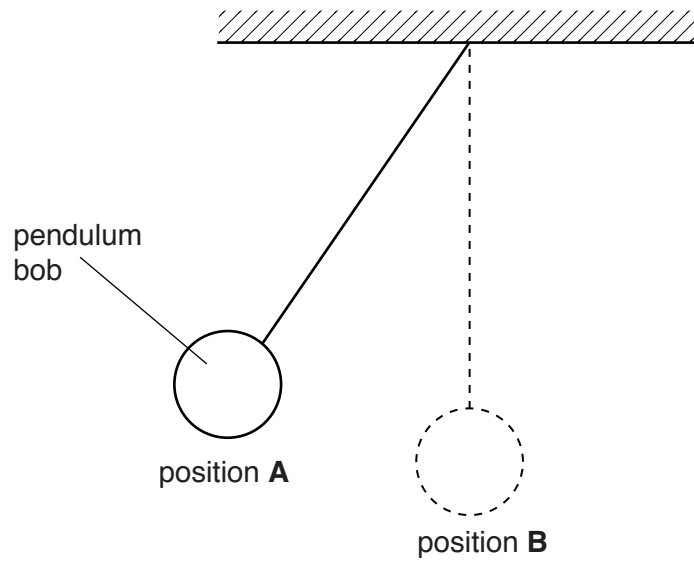

Fig. 9.1

At position **A**, the pendulum changes the direction in which it is moving. The pendulum then accelerates as it moves from position **A** to position **B**.

(a) State what is meant by *acceleration*.

.....
[2]

(b) The pendulum takes 0.4 s to move from position **A** to position **B**.

Calculate the time for the pendulum to return to position **A**.

time = s [1]

(c) Fig. 9.2 shows the pendulum in position **A**.

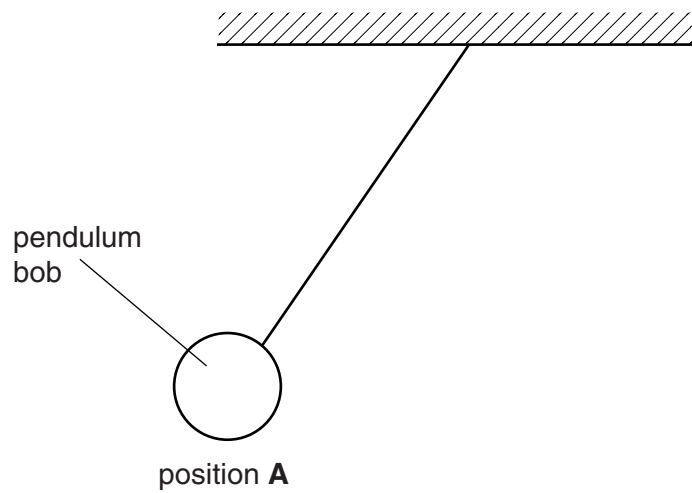

Fig. 9.2

On Fig. 9.2, draw an arrow to show the direction in which the weight of the pendulum bob is acting. [1]

10 Sulfur dioxide is a common pollutant of the atmosphere.

(a) Explain how the sulfur dioxide in the atmosphere is produced.

.....
.....
.....[2]

(b) Sulfur dioxide dissolves in water to produce sulfuric acid.

(i) Name the ion that causes sulfuric acid to be acidic.

.....[1]

(ii) Sulfuric acid reacts with sodium hydroxide to produce sodium sulfate and water.

Balance the equation for this reaction.

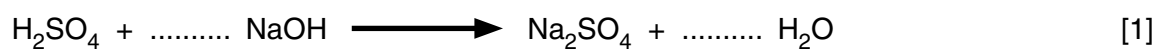

(iii) Name two other substances that react with sulfuric acid to produce sodium sulfate.

..... and[2]

11 (a) Compare the composition of expired air to inspired air.

Write your answers in Table 11.1.

Table 11.1

substance	difference in composition of expired air compared to inspired air
carbon dioxide	
oxygen	
nitrogen	

[3]

(b) The volume of air inspired by a student was measured before and after a long-distance race.

The results are shown in Table 11.2.

Table 11.2

	volume of air inspired in one minute/dm ³
before the race	5.8
after the race	20.5

(i) Calculate the difference in the volume of air inspired in one minute by the student before the race and after the race.

volume = dm³ [1]

(ii) State two **other** ways in which the student's breathing changes from before the race to after the race.

- 1
-
- 2
-[2]

(iii) Explain why an increased volume of air is needed during the race.

-
-
-
-[2]

12 A metre rule is balanced horizontally on a pivot.

An empty measuring cylinder is placed 20 cm from the pivot.

In order to restore balance, a mass of 16 g is placed 30 cm from the pivot, as shown in Fig. 12.1.

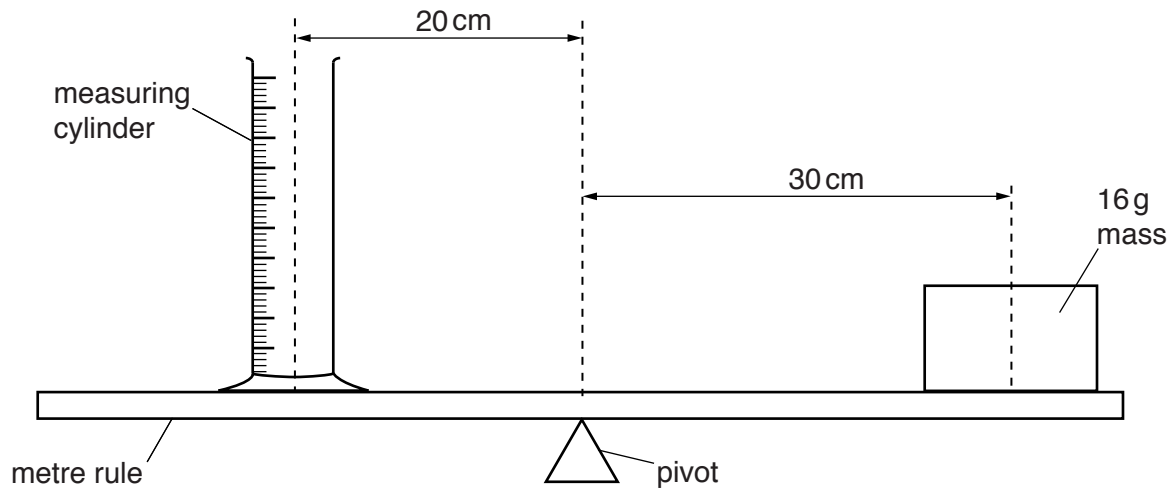

Fig. 12.1

(a) Calculate the mass of the measuring cylinder.

mass = g [2]

(b) The measuring cylinder is removed and some liquid is placed in it, as shown in Fig. 12.2.

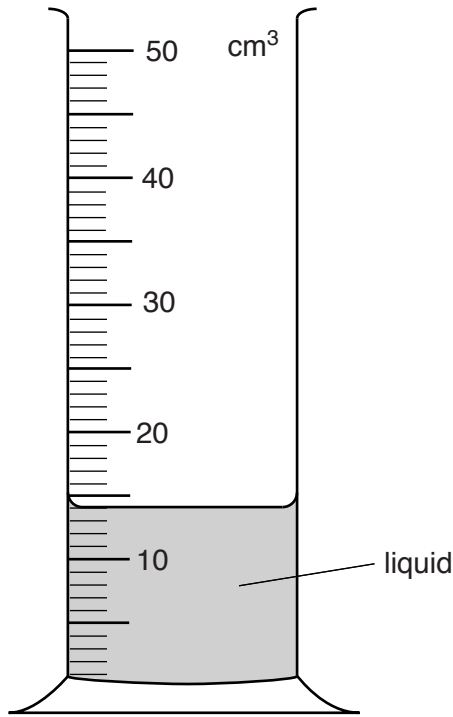

Fig. 12.2

State the volume of liquid in the measuring cylinder.

volume = cm³ [1]

(c) The measuring cylinder containing the liquid is placed on the metre rule.
The 16 g mass remains in its original position.

Explain why the measuring cylinder has to be placed nearer the pivot in order to balance the metre rule.

.....

 [2]

13 Fig. 13.1 shows the arrangement of the electrons in the atoms of six different elements **U – Z**.

The letters are not the chemical symbols of the elements.

atom	U	V	W	X	Y	Z
electron arrangement	2,1	2,5	2,8	2,8,1	2,8,3	2,8,7

Fig. 13.1

Use the letters in Fig. 13.1 to answer the following questions.

Each letter may be used once, more than once or not at all.

(a) Which element has a proton number 17? [1]

(b) Which element combines with three hydrogen atoms to form a covalent compound?
..... [1]

(c) Which two elements are in the same group of the Periodic Table?
..... and [1]

(d) Which element does not form an oxide? [1]

(e) Deduce the formula of the compound formed by elements **Y** and **Z**.
.....[1]

14 An object falls through a vertical distance of 2.5 m.

(a) State the type of energy lost by the object as it falls.
.....[1]

(b) The work done on the object by the force of gravity is 15 J.

Calculate the weight of the object.

weight = N [2]

15 Use words from the list to complete the sentences below.

- amplitudes** **frequencies** **reflection** **refraction**
speed **vibrations** **wavelengths**

Each word may be used once, more than once or not at all.

Electromagnetic waves all have the same in a vacuum.

Gamma-rays always have smaller than radiowaves.

The change in the direction of a light ray when incident on a plane mirror is called

..... [3]

16 Complete Table 16.1 by naming the biological structures responsible for the described processes.

Table 16.1

biological structure	process
	breaks down alcohol
	controls the passage of substances in and out of cells
	controls the size of the pupil in the eye
	excretes urea
	causes blood to clot
	stores bile

[6]

17 In the reactivity series for metals, aluminium is above iron but aluminium is resistant to corrosion.

(a) Explain why aluminium is resistant to corrosion.

.....

 [2]

(b) State one use of aluminium.

..... [1]

18 Fig. 18.1 shows light entering and passing through a parallel-sided glass block.

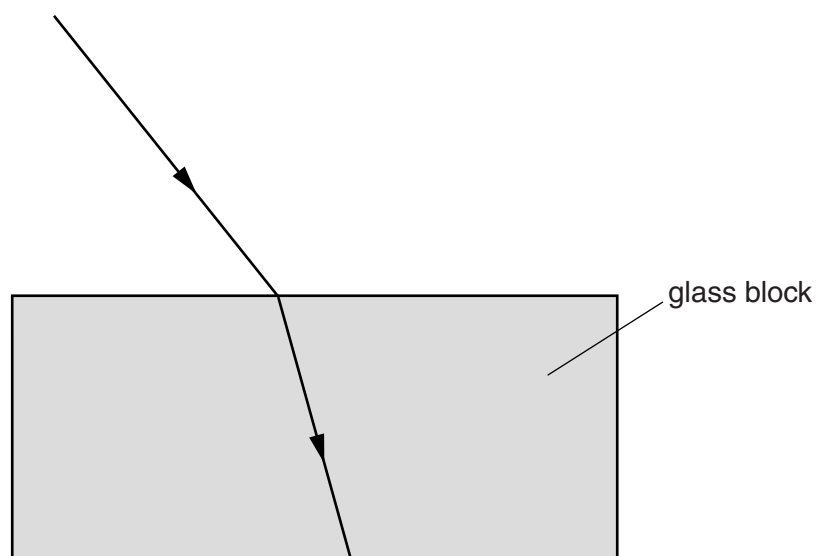

Fig. 18.1

On Fig. 18.1,

- (a) draw the normal where the ray is incident on the block, [1]
- (b) label the angle of incidence where the ray is incident on the block, [1]
- (c) draw the ray after it emerges from the block. [1]

19 Fig. 19.1 shows how the thickness of the lining of a woman's uterus changes during her menstrual cycle.

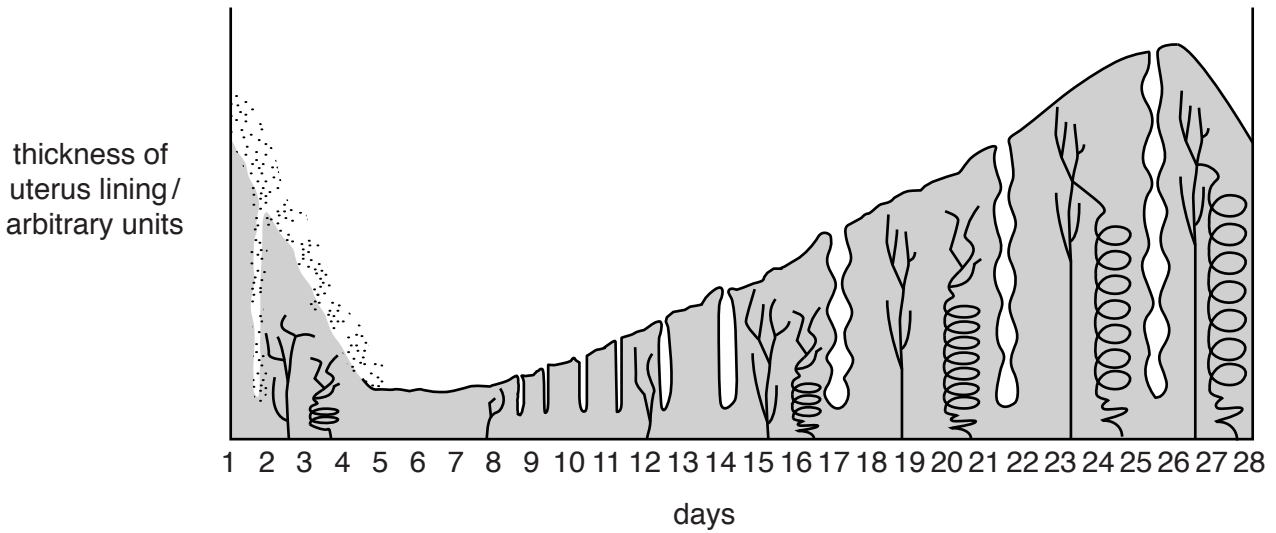

Fig. 19.1

- (a) (i) On Fig. 19.1, draw a circle round a day to show when menstruation begins. [1]
- (ii) Use the information in Fig. 19.1 to suggest a day when sexual intercourse could result in the formation of a zygote.

day [1]

(b) One method of birth control is to avoid sexual intercourse during a woman's fertile days.

State two other methods of birth control.

- 1
- 2

[2]

(c) Syphilis is a disease spread during sexual intercourse.

(i) Describe one sign of syphilis.

.....

(ii) State the treatment for syphilis.

.....

[2]

20 Fig. 20.1 names gases, some tests for gases, and the results of these tests.

On Fig. 20.1, draw lines to link each gas to the test for the gas and the result for the test if the gas is present.

The lines for one gas have been completed for you.

gas	test	result
carbon dioxide	burning splint	goes milky
sulfur dioxide	limewater	relights
hydrogen	glowing splint	turns red
oxygen	blue litmus	burns with a pop
ammonia	red litmus	turns blue

Fig. 20.1

[4]

21 An isotope of plutonium is plutonium-238 (${}^{238}_{94}\text{Pu}$).

(a) State the number of neutrons in a ${}^{238}_{94}\text{Pu}$ nucleus. [1]

(b) A nucleus of ${}^{238}_{94}\text{Pu}$ decays by emitting an alpha-particle.

State the number of protons and the number of neutrons in an alpha-particle.

number of protons

number of neutrons [1]

(c) The half-life of plutonium-238 is 88 years.

A sample of plutonium-238 emitted 3200 alpha-particles per second, 352 years ago.

Calculate the number of alpha-particles per second that the sample now emits.

number per second = [2]

BLANK PAGE

Permission to reproduce items where third-party owned material protected by copyright is included has been sought and cleared where possible. Every reasonable effort has been made by the publisher (UCLES) to trace copyright holders, but if any items requiring clearance have unwittingly been included, the publisher will be pleased to make amends at the earliest possible opportunity.

To avoid the issue of disclosure of answer-related information to candidates, all copyright acknowledgements are reproduced online in the Cambridge International Examinations Copyright Acknowledgements Booklet. This is produced for each series of examinations and is freely available to download at www.cie.org.uk after the live examination series.

Cambridge International Examinations is part of the Cambridge Assessment Group. Cambridge Assessment is the brand name of University of Cambridge Local Examinations Syndicate (UCLES), which is itself a department of the University of Cambridge.

DATA SHEET
The Periodic Table of the Elements

Group																						
I	II	III	IV	V	VI	VII	0															
7 Li Lithium 3	9 Be Beryllium 4	1 H Hydrogen 1	11 B Boron 5	12 C Carbon 6	14 N Nitrogen 7	16 O Oxygen 8	19 F Fluorine 9	20 Ne Neon 10	4 He Helium 2													
23 Na Sodium 11	24 Mg Magnesium 12	27 Al Aluminium 13	28 Si Silicon 14	31 P Phosphorus 15	32 S Sulfur 16	35.5 Cl Chlorine 17	36 Ar Argon 18															
39 K Potassium 19	40 Ca Calcium 20	45 Sc Scandium 21	48 Ti Titanium 22	51 V Vanadium 23	52 Cr Chromium 24	55 Mn Manganese 25	56 Fe Iron 26	59 Co Cobalt 27	59 Ni Nickel 28	64 Cu Copper 29												
85 Rb Rubidium 37	88 Sr Strontium 38	89 Y Yttrium 39	91 Zr Zirconium 40	93 Nb Niobium 41	96 Mo Molybdenum 42	101 Ru Ruthenium 44	103 Rh Rhodium 45	106 Pd Palladium 46	108 Ag Silver 47	112 Cd Cadmium 48												
133 Cs Caesium 55	137 Ba Barium 56	139 La Lanthanum 57	178 Hf Hafnium 72	181 Ta Tantalum 73	184 W Tungsten 74	190 Os Osmium 76	192 Ir Iridium 77	195 Pt Platinum 78	197 Au Gold 79	201 Hg Mercury 80												
223 Fr Francium 87	226 Ra Radium 88	227 Ac Actinium 89									204 Tl Thallium 81	207 Pb Lead 82	209 Bi Bismuth 83	210 At Astatine 85	222 Rn Radon 86							
										140 Ce Cerium 58	141 Pr Praseodymium 59	144 Nd Neodymium 60	150 Sm Samarium 62	152 Eu Europium 63	157 Gd Gadolinium 64	159 Tb Terbium 65	162 Dy Dysprosium 66	165 Ho Holmium 67	167 Er Erbium 68	169 Tm Thulium 69	173 Yb Ytterbium 70	175 Lu Lutetium 71
										232 Th Thorium 90	231 Pa Protactinium 91	238 U Uranium 92	244 Pu Plutonium 94	243 Am Americium 95	247 Cm Curium 96	247 Bk Berkelium 97	251 Cf Californium 98	252 Es Einsteinium 99	257 Fm Fermium 100	258 Md Mendelevium 101	259 No Nobelium 102	260 Lr Lawrencium 103

* 58–71 Lanthanoid series
† 90–103 Actinoid series

a X b
 Key a = relative atomic mass
 X = atomic symbol
 b = atomic (proton) number

The volume of one mole of any gas is 24 dm³ at room temperature and pressure (r.t.p.).